

SEARCH FOR NEW PARTICLES OR GAUGE BOSONS DECAYING INTO DILEPTONS/DIJETS AT THE TEVATRON

Mario Paolo Giordani
University of California, Davis

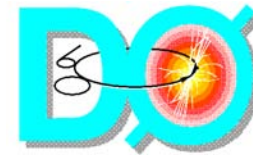

on behalf of the CDF and DO Collaborations

EUROPEAN PHYSICAL SOCIETY – AACHEN, GERMANY – JULY 17-23, 2003

International Europhysics Conference on High Energy Physics

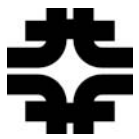

OUTLINE

- ACCELERATOR PERFORMANCE
- DETECTORS
- DIJET RESONANCES
 - AXIGLUONS
 - FLAVOUR UNIVERSAL COLORONS
 - EXCITED QUARKS
 - COLOR OCTET TECHNI- ρ
 - E_6 DIQUARKS
 - Z', W' GAUGE BOSONS
 - RANDALL-SUNDRUM GRAVITONS
- DILEPTON RESONANCES
 - Z' GAUGE BOSONS
 - RANDALL-SUNDRUM GRAVITONS
- CONCLUDING REMARKS



The Tevatron II Accelerator Complex

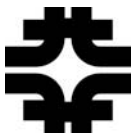

✓ ACCELERATOR PERFORMANCE

□ ACHIEVED:

⊛ $\int \mathcal{L} dt / \text{week} \simeq 9 \text{ pb}^{-1}$

⊛ $\mathcal{L} \simeq 4.9 \text{e}31 \text{ cm}^{-2} \text{ s}^{-1} \Rightarrow \bar{N}(\text{interactions}/\text{beam-cross}) \simeq 1.5$

□ BY END SUMMER 2003: $\int \mathcal{L} dt \simeq 280 \text{ pb}^{-1}$

□ LONG(ER)-TERM PLAN: MAJOR EFFORT TO IMPROVE \bar{p} CHAIN

⊛ INTEGRATE RECYCLER

⊛ ENABLE ELECTRON COOLING

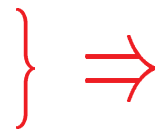

$\mathcal{L} \longrightarrow 3 \text{e}32 \text{ cm}^{-2} \text{ s}^{-1}$

$\bar{N}(\text{interactions}/\text{beam-cross}) \longrightarrow 10$

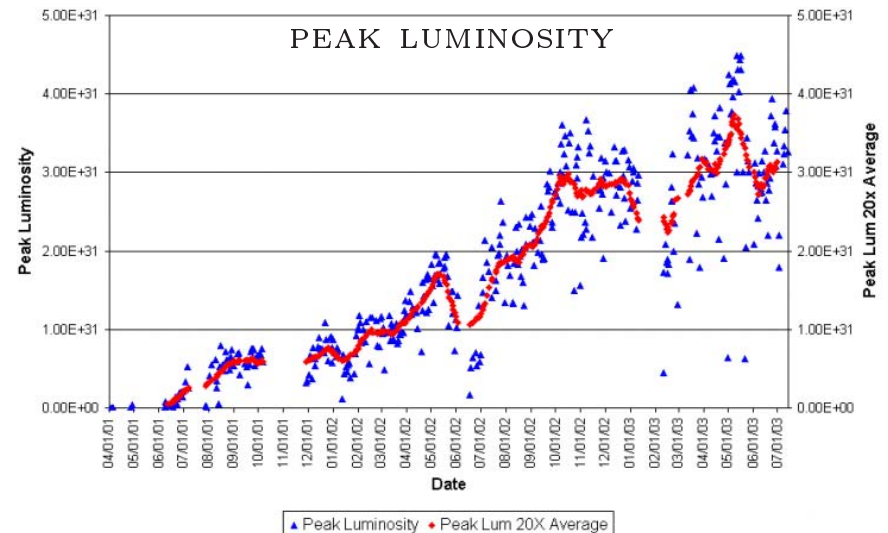
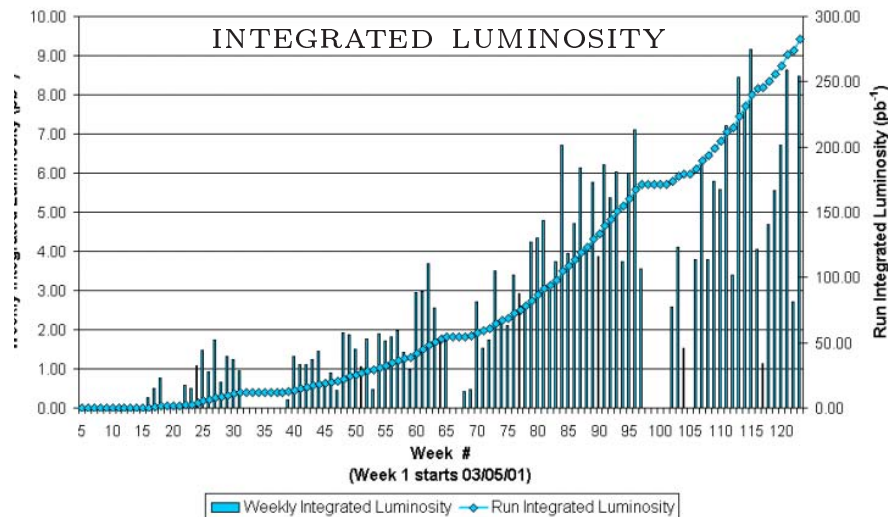

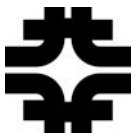

✓ TEVATRON DETECTORS

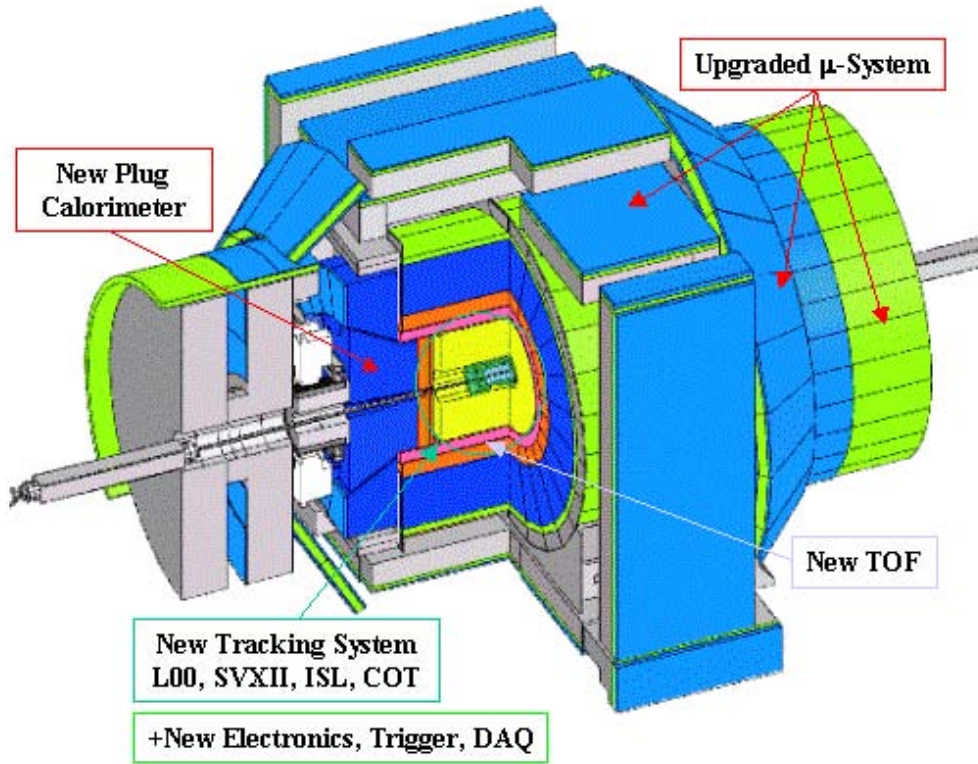

CDF

- μ COVERAGE UP TO $|\eta| \simeq 1.5$
- ELECTRON COVERAGE UP TO $|\eta| \simeq 2.5$
- JET RECONSTRUCTION UP TO $|\eta| \simeq 3.0$

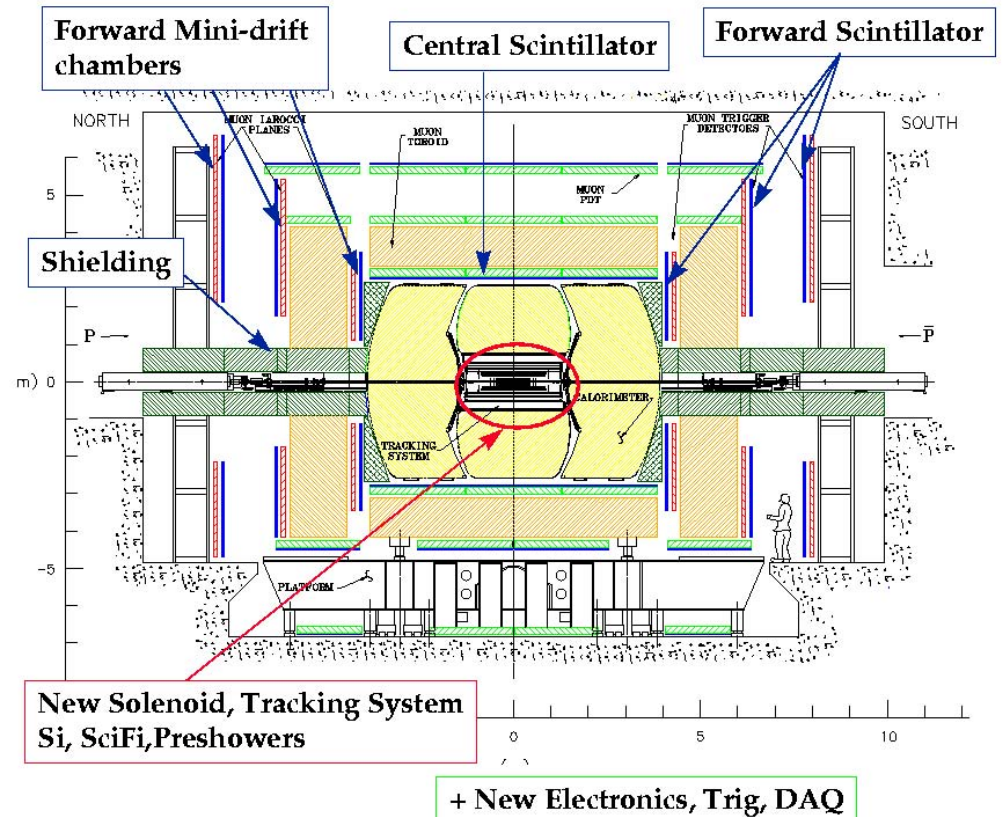

DO

- μ COVERAGE UP TO $|\eta| \simeq 2$
- ELECTRON COVERAGE UP TO $|\eta| \simeq 3.0$
- JET RECONSTRUCTION UP TO $|\eta| \simeq 3.0$

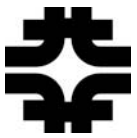

✓ **NEW PARTICLES DECAYING TO DIJETS – 1**

- FOR MANY CLASSES OF NEW PARTICLES **B.R.(X → jj)** IS LARGE
- QCD BACKGROUND IS HUGE...
- ...HOWEVER, ALL PARTICLES NARROWER THAN $\sigma_{jj}^{\text{CDF}} (\sim 0.1 \cdot M_{jj})$
 - ⊗ WILL BE RECONSTRUCTED EQUALLY WIDE
- SAME LINESHAPE (SCULPTED BY σ_{jj}) FITS ALL
- GENERAL PROCEDURE TO SET LIMITS ON **$\sigma(\text{p}\bar{\text{p}} \rightarrow \text{X}) \cdot \text{B.R.}(\text{X} \rightarrow jj)$** FOR:

AXIGLUONS	$A \rightarrow q\bar{q}$	$\Gamma_A/2 \sim 0.05 \cdot M_A$	(CHIRAL COLOUR)
COLORONS	$C \rightarrow q\bar{q}$	$\Gamma_C/2 \sim 0.05 \cdot M_C$	(ETC – TECHNICOLOR)
EXCITED QUARKS	$q^* \rightarrow qg$	$\Gamma_{q^*}/2 \sim 0.02 \cdot M_{q^*}$	(COMPOSITENESS)
COLOR OCTET TECHNI- ρ	$\rho_T \rightarrow g \rightarrow q\bar{q}, g\bar{g}$	$\Gamma_{\rho_T}/2 \sim 0.01 \cdot M_{\rho_T}$	(TECHNICOLOR)
E_6 DIQUARKS	$D \rightarrow u\bar{d}$	$\Gamma_D/2 \sim 0.004 \cdot M_D$	(STRING THEORY)
NEW GAUGE BOSONS	$Z'(W') \rightarrow q\bar{q}^{(\prime)}$	$\Gamma_{V'}/2 \sim 0.014 \cdot M_{V'}$	(VARIOUS)
RS GRAVITON	$G \rightarrow q\bar{q}, g\bar{g}$	$\Gamma_G/2 \sim 0.06 \cdot M_G$	(RANDALL-SUNDRUM)

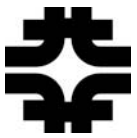

✓ NEW PARTICLES DECAYING TO DIJETS – 2

- STARTING POINT: INCLUSIVE JET SAMPLES ($E_T > 20, 50, 70, 100$ GeV)
- COSMIC CLEAN-UP REQUIRES $\cancel{E}_T / \sqrt{\sum E_T} < 6$
- TWO LEADING JETS (CONE 0.7, E_T -CORRECTED) WITH: $|\eta_{jet}| < 2$
- REDUCTION OF QCD t-CHANNEL CONTRIBUTION: $|\cos \theta^*| < 2/3$

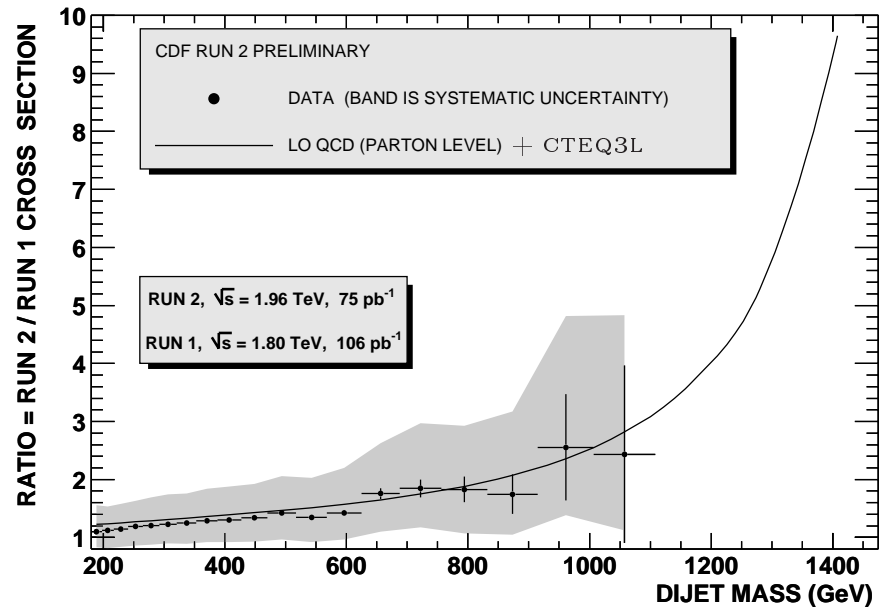
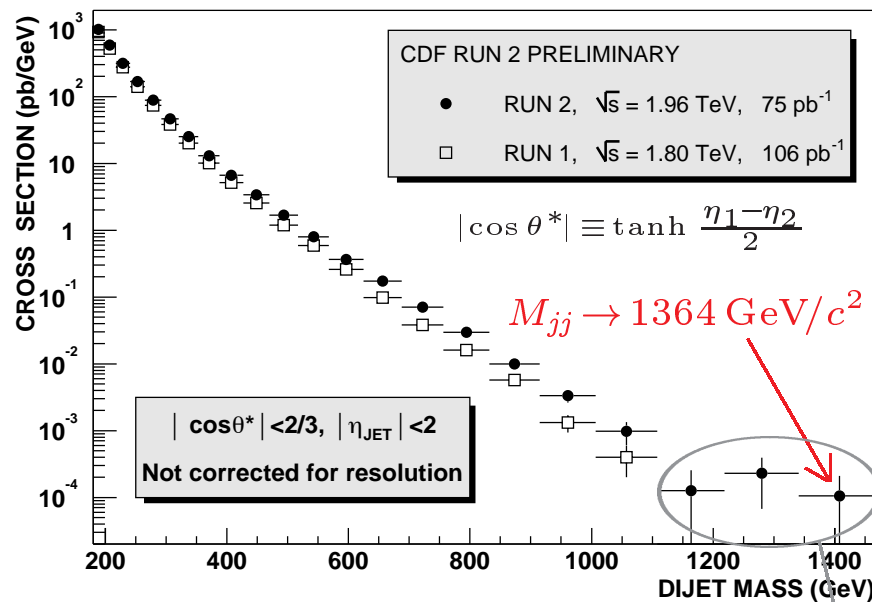

HIGHEST MASS EVENTS ($M_{jj} \sim 0.7\sqrt{s}$) PROBES x UP TO 0.7

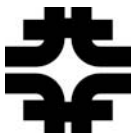

✓ NEW PARTICLES DECAYING TO DIJETS – 3

- (LO) QCD-INSPIRED BACKGROUND PARAMETRIZATION:

$$\left. \frac{d\sigma}{dM} \right|_{dijet} = \frac{p_0 (1 - M/\sqrt{s} - p_1 M^2/s)^{p_2}}{M^{p_3}}$$

$\sim (1-x)^n$ PDF BEHAVIOUR

MIMICS QCD ME

- BACKGROUND PARAMETRIZATION FITS WELL ON DATA

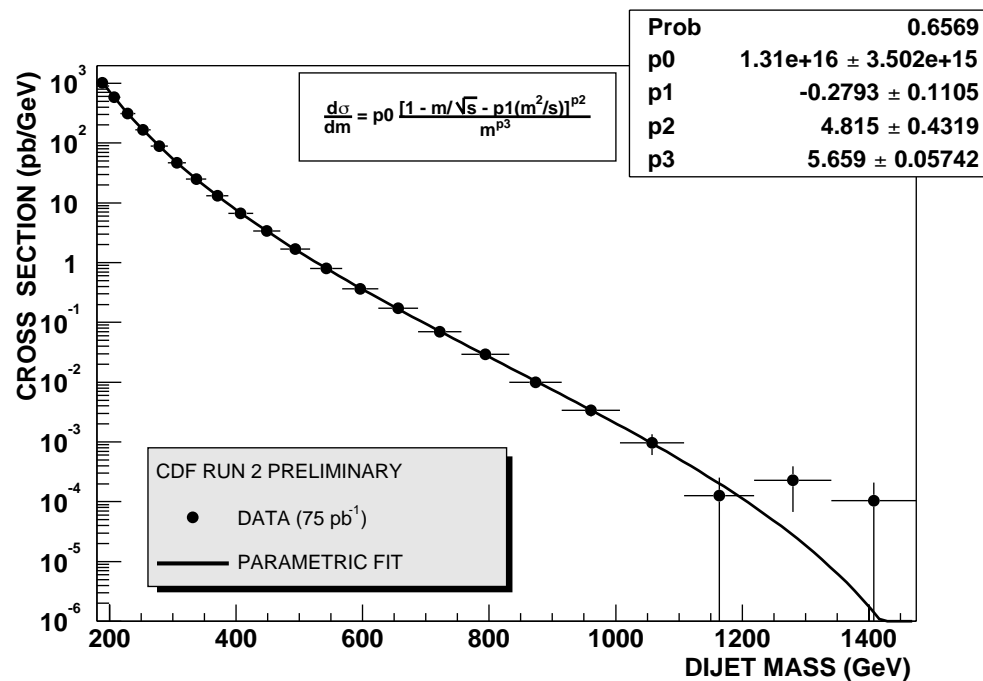

NO EVIDENCE OF NEW PHYSICS

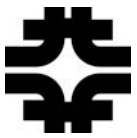

✓ NEW PARTICLES DECAYING TO DIJETS – 4

□ ADD NARROW RESONANCE TO BACKGROUND PARAMETRIZATION:

- ⊗ CDF DIJET MASS RESOLUTION DOMINATES THE LINESHAPE
- ⊗ SHAPE PARAMETRIZED BY $q^* \rightarrow qg$ THROUGH DETECTOR SIMULATION
- ⊗ WELL REPRESENTED BY A 10%-CORE GAUSSIAN + LOW- M_{jj} RADIATIVE TAIL

□ BINNED MAXIMUM LIKELIHOOD FIT:

$$\mathcal{L} = \prod_i P_i = \prod_i \frac{\mu_i^{n_i} e^{-\mu_i}}{n_i!}$$

n_i : OBSERVED EVENTS } IN i -TH M_{jj} BIN

$\mu_i = N_i^B + \alpha N_i^S$

NORMALIZED TO
SIGNAL X-SECTION

BACKGROUND
PARAMETRIZATION

- ⊗ ESTIMATE $\bar{p}_i(\bar{\alpha})$

- ⊗ α_{95} FROM $\int_0^{\alpha_{95}} \mathcal{L}(\bar{p}_i, \alpha) d\alpha / \int_0^{\infty} \mathcal{L}(\bar{p}_i, \alpha) d\alpha = 0.95$

- SET 95% C.L. LIMITS AS $\sigma_{95} = \alpha_{95} \cdot \sigma_{signal}$

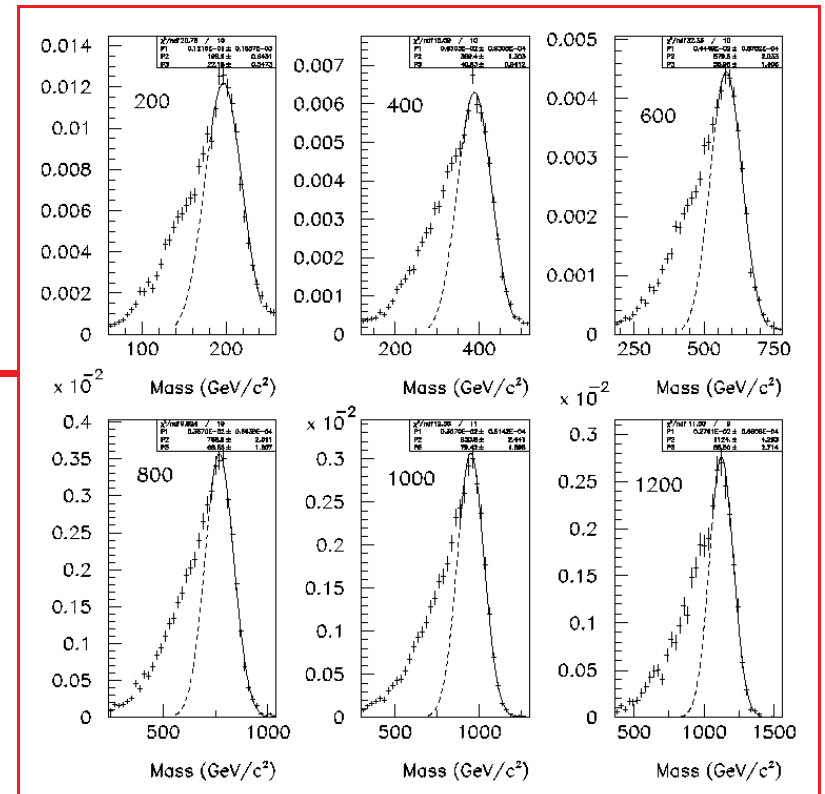

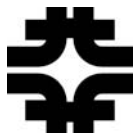

✓ NEW PARTICLES DECAYING TO DIJETS – 5

NEW PARTICLE	95% C.L. EXCLUDED MASS [GeV/c ²]
AXIGLUON [†]	200 < M _A < 1130
COLORON	200 < M _C < 1130
EXCITED QUARK	200 < M _{q*} < 760
TECHNI-ρ	260 < M _{ρT} < 640
E ₆ DIQUARK	280 < M _D < 420
GAUGE BOSONS	300 < M _{W'} < 410

† PREVIOUS CDF MEASUREMENT
 120 GeV/c² < M_A (@ 95% C.L.)

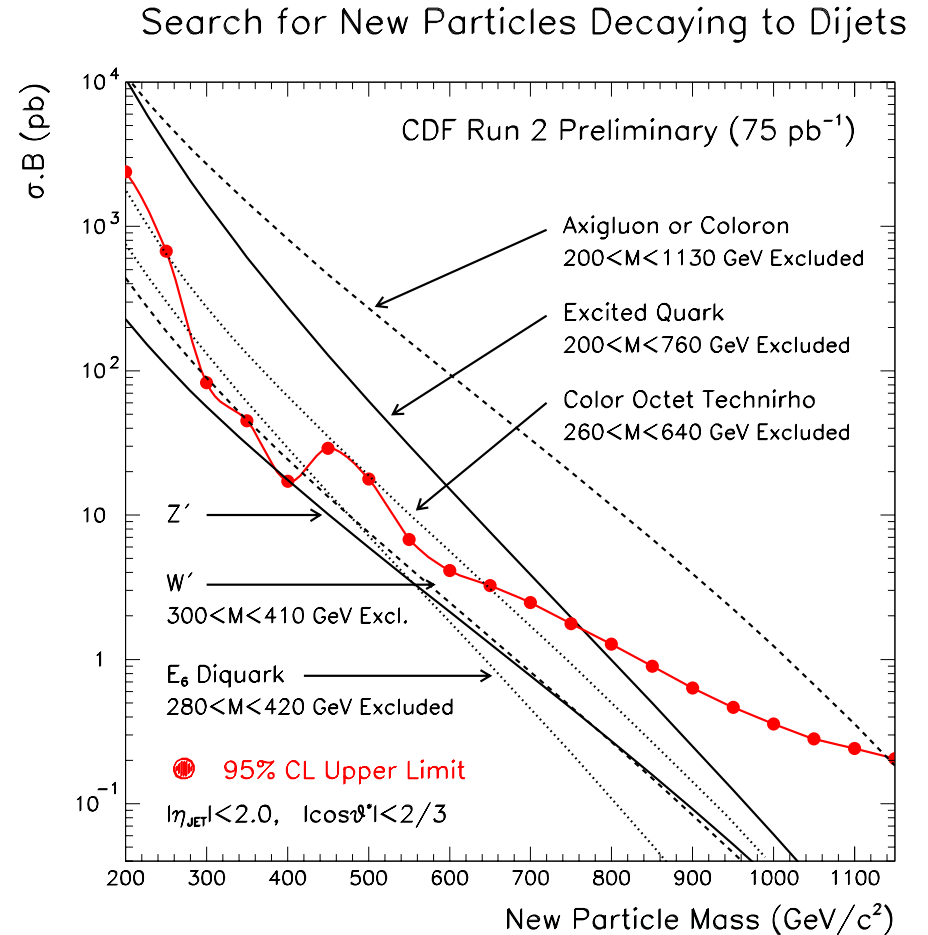

LEADING ORDER MC (CTEQ2L) + 1-LOOP α_S – RENORMALIZATION SCALE @ μ = M
 K-FACTOR APPLIED FOR NEW GAUGE BOSONS

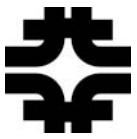

✓ NEW PARTICLES DECAYING TO DIJETS – 6

Search for RS Gravitons Decaying to Dijets

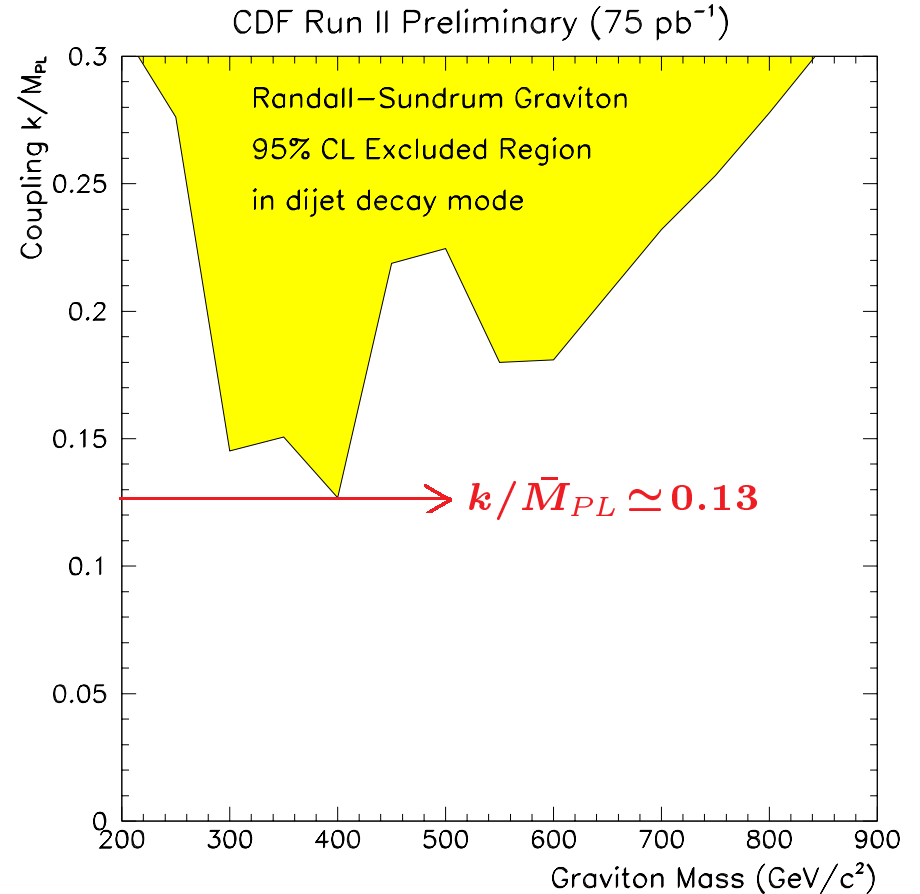
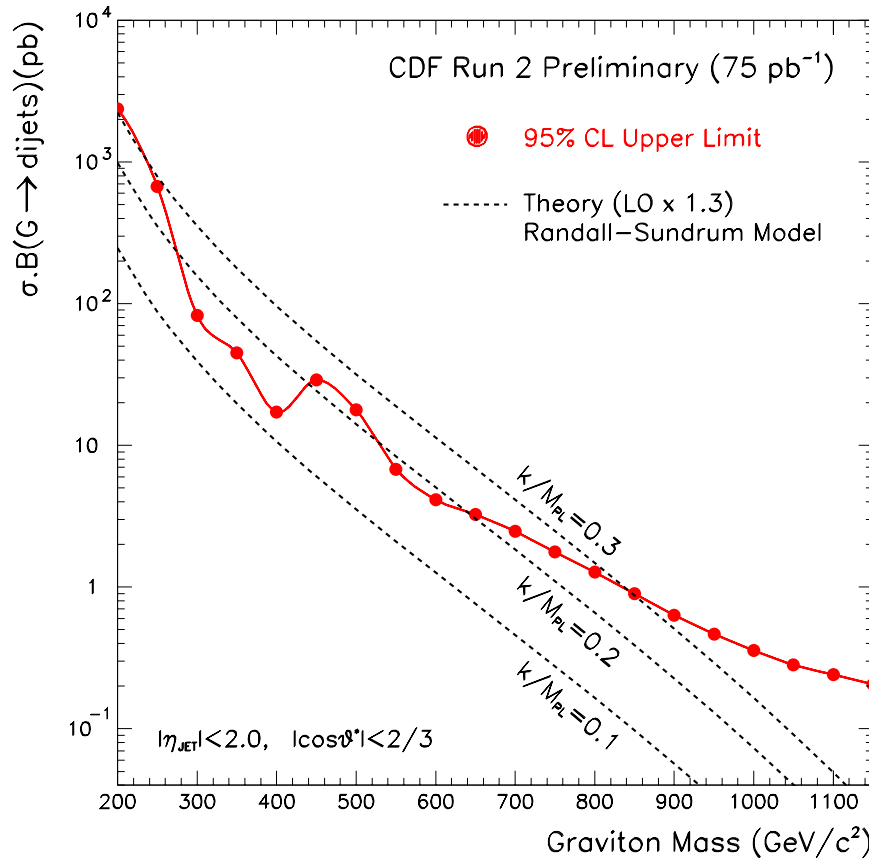

$220 \text{ GeV}/c^2 < M_G < 840 \text{ GeV}/c^2$ EXCLUDED @ 95% C.L. FOR $k/\bar{M}_{PL} = 0.3$

NEXT-TO-LEADING ORDER MC (CTEQ6L) – RENORMALIZATION SCALE @ $\mu = M_G$

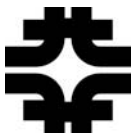

✓ NEW PARTICLES DECAYING TO DILEPTONS

- SIGNALLED BY ANOMALOUS HIGH- $M_{\ell\ell}$ RESONANCES
- MODELS PREDICTS $\text{B.R.}(X \rightarrow \ell^+ \ell^-)$ AS A FUNCTION OF M_X
- DRELL-YAN, QCD AND EWK PROCESSES CONTRIBUTE TO BACKGROUND
- GENERAL SEARCH FOR DILEPTON BUMPS INTERPRETED IN TERMS OF:

NEW GAUGE BOSONS $Z' \rightarrow \ell^+ \ell^-$ (VARIOUS MODELS)

RS GRAVITON $G \rightarrow \ell^+ \ell^-$ (RANDALL-SUNDRUM)

- SET LIMITS ON $\sigma(p\bar{p} \rightarrow X) \cdot \text{B.R.}(X \rightarrow \ell^+ \ell^-)$
- SEARCHES PERFORMED IN $\ell = e, \mu$ CHANNELS

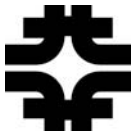

✓ **NEW PARTICLES DECAYING TO DIELECTRONS – 1**

□ **STARTING POINT: INCLUSIVE HIGH- P_T ELECTRON SAMPLES**

CDF	$E_T > 18 \text{ GeV}, \eta < 1.1$	$\int \mathcal{L} dt = 72 \text{ pb}^{-1}$	← TRACK @ L1 & L2
	$E_T > 70 \text{ GeV}, \eta < 1.1$		
DO	$E_T > 20 \text{ GeV}, \eta < 3.0$	$\int \mathcal{L} dt = 50 \text{ pb}^{-1}$	

□ **OFFLINE DIELECTRON SELECTION**

CDF	$E_T(e_1) > 25 \text{ GeV}, \eta < 1.1$	$\int \mathcal{L} dt = 72 \text{ pb}^{-1}$	← BC TRACK W/ $P_T > 13 \text{ GeV}/c$
	$E_T(e_2) > 25 \text{ GeV}, \eta < 1.1 \text{ OR } 1 < \eta < 3$		
DO	$E_T(e_1, e_2) > 25 \text{ GeV}, \eta < 1.1 \text{ OR } 1.5 < \eta < 2.5$		

⊗ ID SELECTION INCLUDES E_{had}/E_{em} , E/P , ISOLATION, SHOWER PROFILE χ^2

□ **BACKGROUND TREATMENT:**

- ⊗ $\cancel{E}_T / \sqrt{\sum E_T} < 2.5$ REDUCES $W+jets$
 - ⊗ QCD CONTAMINATION ESTIMATED BY REVERSING e_1, e_2 ISOLATION CUTS
 - ⊗ QCD BACKGROUND FROM DIJET EVENTS ⊗ ELECTRON FAKE-RATE → **DO**
- } **CDF**

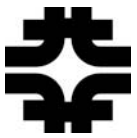

✓ NEW PARTICLES DECAYING TO DIELECTRONS – 2

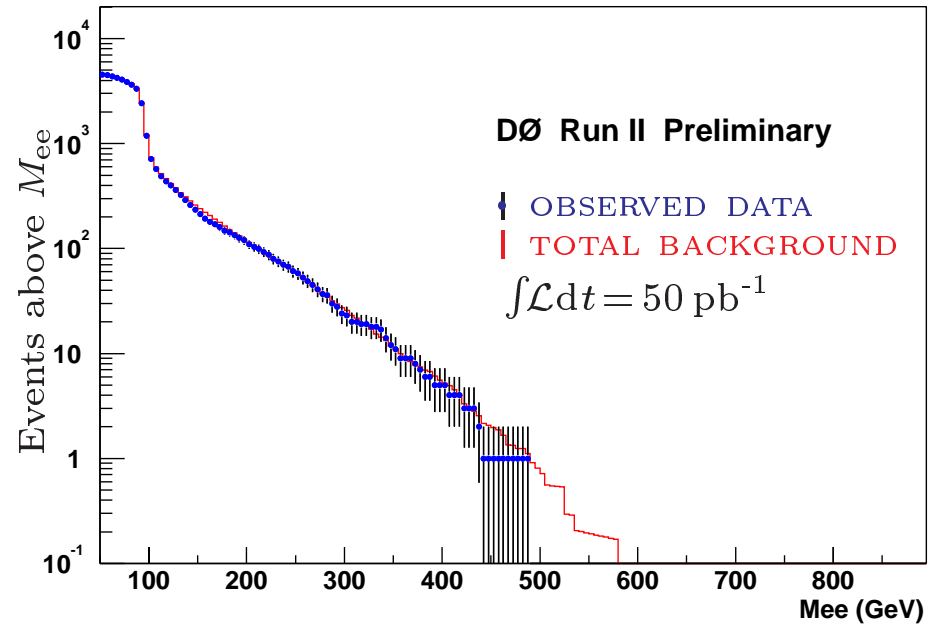
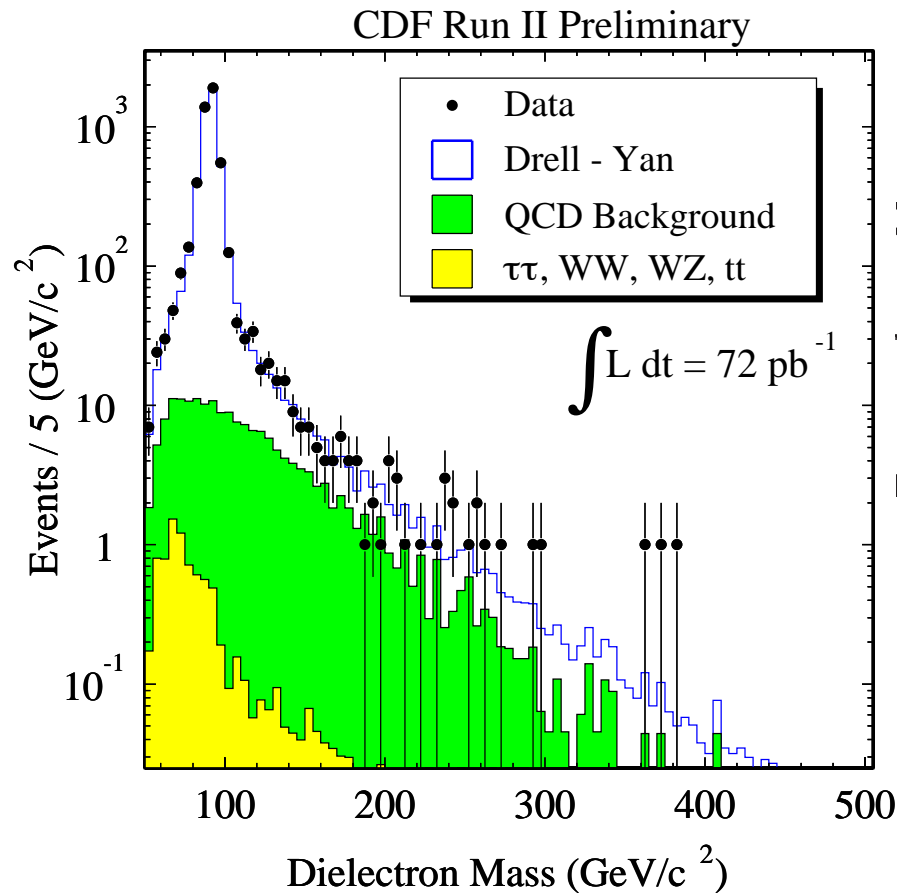

	$M_{ee} [\text{GeV}/c^2]$	N_{exp}	N_{obs}
CDF	> 150	63.8	63
DØ		239	213

NO SIGNIFICANT EXCESS OBSERVED

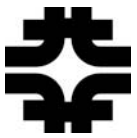

NEW PARTICLES DECAYING TO DIELECTRONS – 3

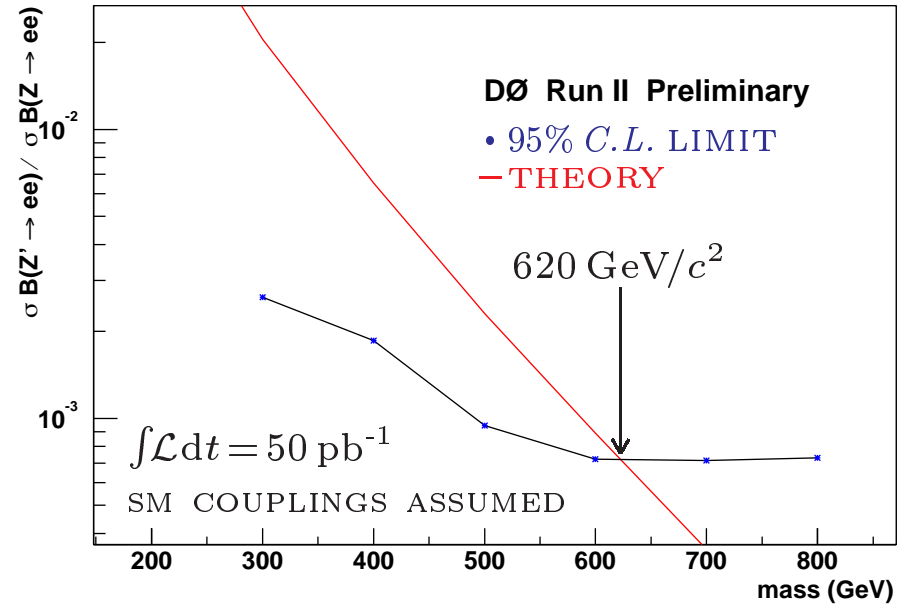
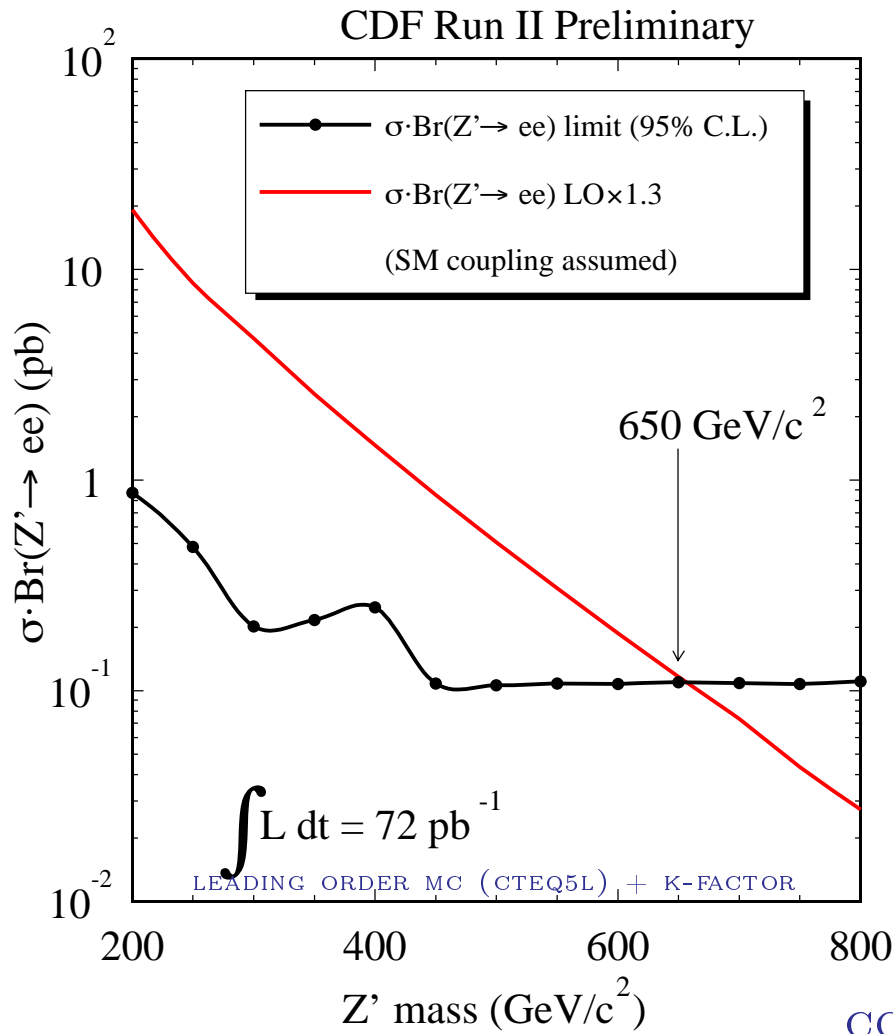

95% C.L. LIMITS ON POISSON PROCESS

$$Z'_{\text{SM-like}} \rightarrow e^+e^-$$

CROSS-CHECK: $\sigma \cdot B.R.(Z \rightarrow e^+e^-)$

COMPATIBLE WITH CDF & DO MEASUREMENTS

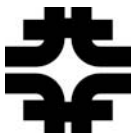

✓ NEW PARTICLES DECAYING TO DIMUONS – 1

- STARTING POINT: INCLUSIVE HIGH- P_T MUON SAMPLES

$$\text{CDF} \left| \begin{array}{ll} P_T > 18 \text{ GeV}/c^2, |\eta| < 0.6 & \int \mathcal{L} dt = 72 \text{ pb}^{-1} \\ P_T > 18 \text{ GeV}/c^2, 0.6 < |\eta| < 1 & \int \mathcal{L} dt = 56 \text{ pb}^{-1} \end{array} \right.$$

- OFFLINE DIMUON SELECTION

$$\text{CDF} \left| P_T(\mu_1, \mu_2) > 20 \text{ GeV}/c^2, |\eta| < 0.6 \text{ OR } 0.6 < |\eta| < 1 \right.$$

- ⊛ ID SELECTION INCLUDES  TRACK-STUB MATCHING QUALITY
 E_{em}, E_{had} COMPATIBLE W/ MIP

- COSMIC BACKGROUND REMOVAL:

- ⊛ TRACK-BASED: “ATTACH” MUONS TO BEAMLINER/VERTEX (d_0, z_0)
- ⊛ TIMING-BASED: RELY ON TOF AND HADRON TDC INFORMATION

- OTHER BACKGROUNDS: ESSENTIALLY DY (QCD NEGLIGIBLE)

ONLY BACKGROUND @ HIGH- $M_{\mu\mu}$ 

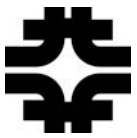

✓ NEW PARTICLES DECAYING TO DIMUONS – 2

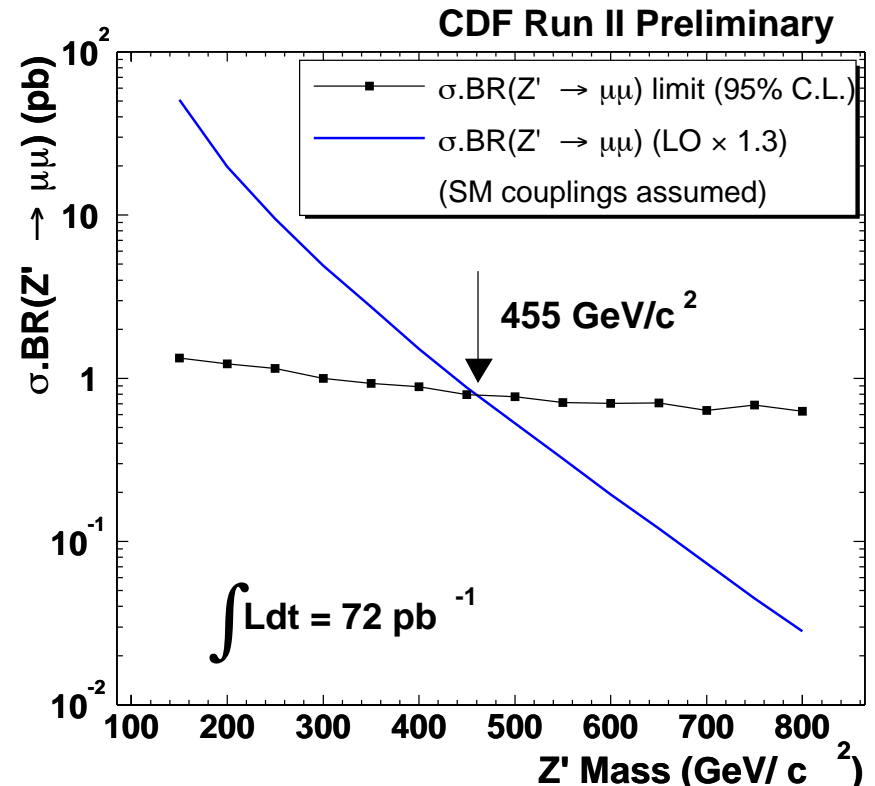
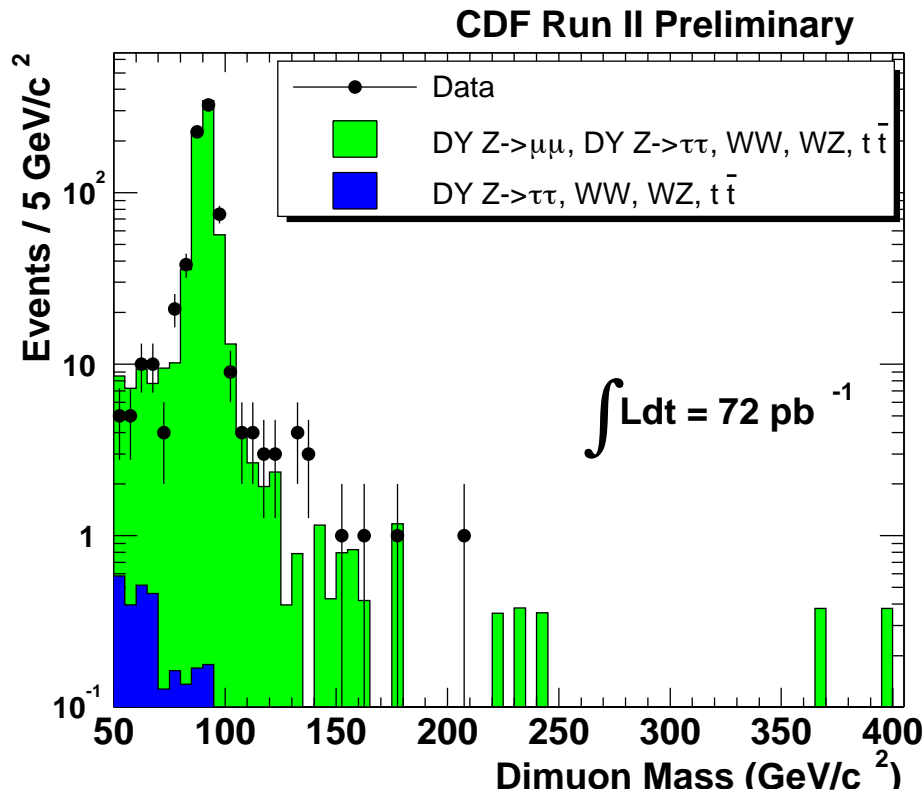

	$M_{\mu\mu} [\text{GeV}/c^2]$	N_{exp}	N_{obs}
CDF	> 150	5.2	4

CROSS-CHECK: $\sigma \cdot B.R.(Z \rightarrow \mu^+ \mu^-)$
 COMPATIBLE WITH CDF MEASUREMENTS

NO EXCESS OBSERVED

95% C.L. LIMITS ON POISSON PROCESS

$$Z'_{SM-like} \rightarrow \mu^+ \mu^-$$

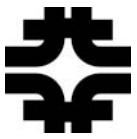

✓ NEW PARTICLES DECAYING TO DILEPTONS – 1

◻ COMBINED DIELECTRON + DIMUON CHANNEL Z' SENSITIVITY

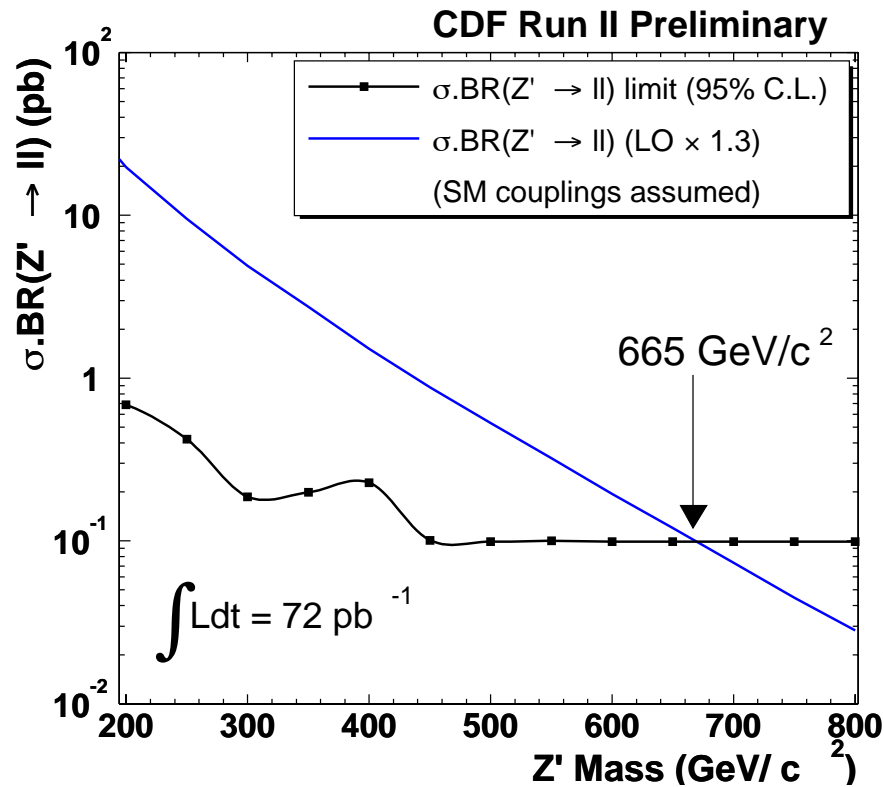

SM-COUPLING Z'

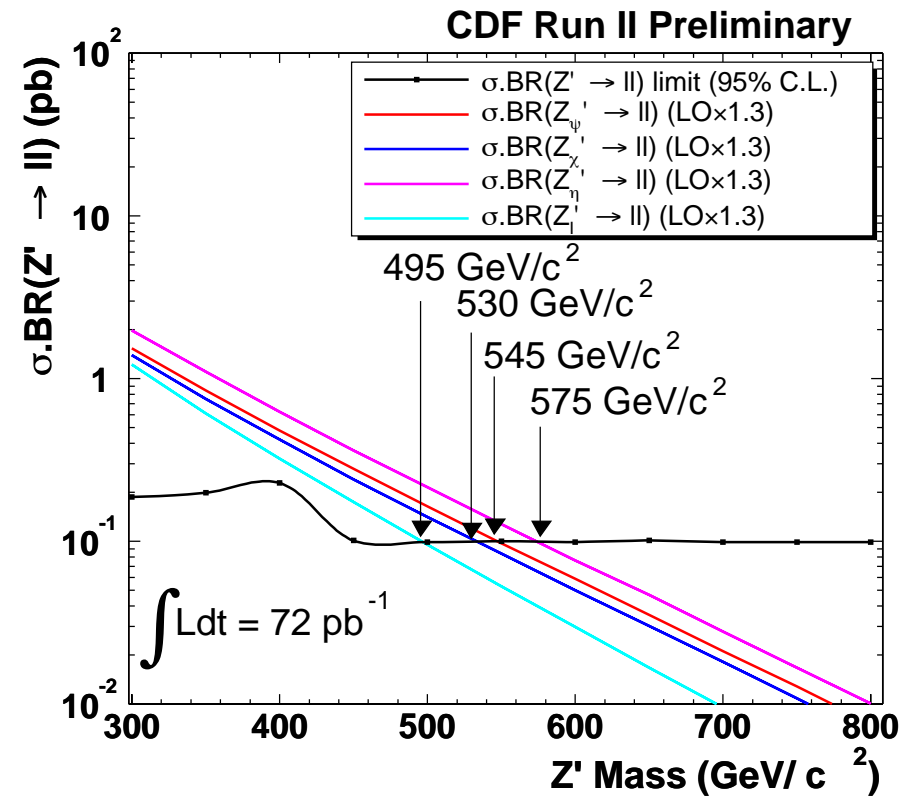

E_6 MODEL Z'

LEADING ORDER MC (CTEQ5L) + K-FACTOR

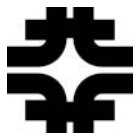

✓ NEW PARTICLES DECAYING TO DILEPTONS – 2

◻ COMBINED DIELECTRON + DIMUON CHANNEL RS-GRAVITON SENSITIVITY

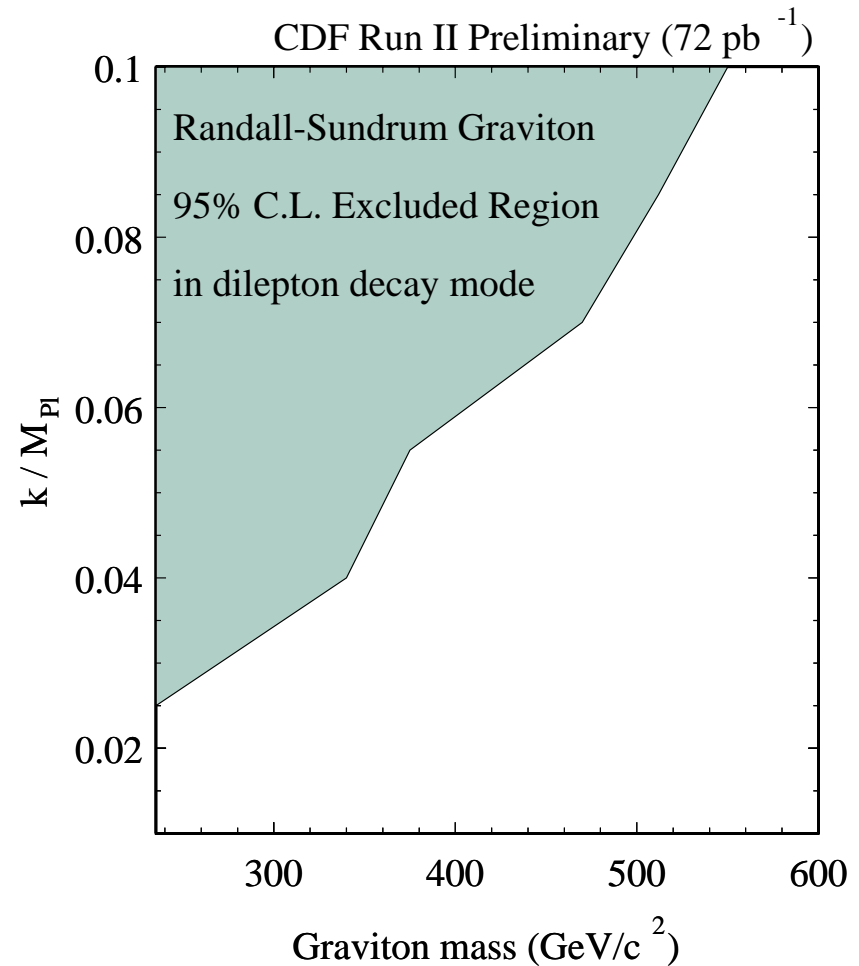
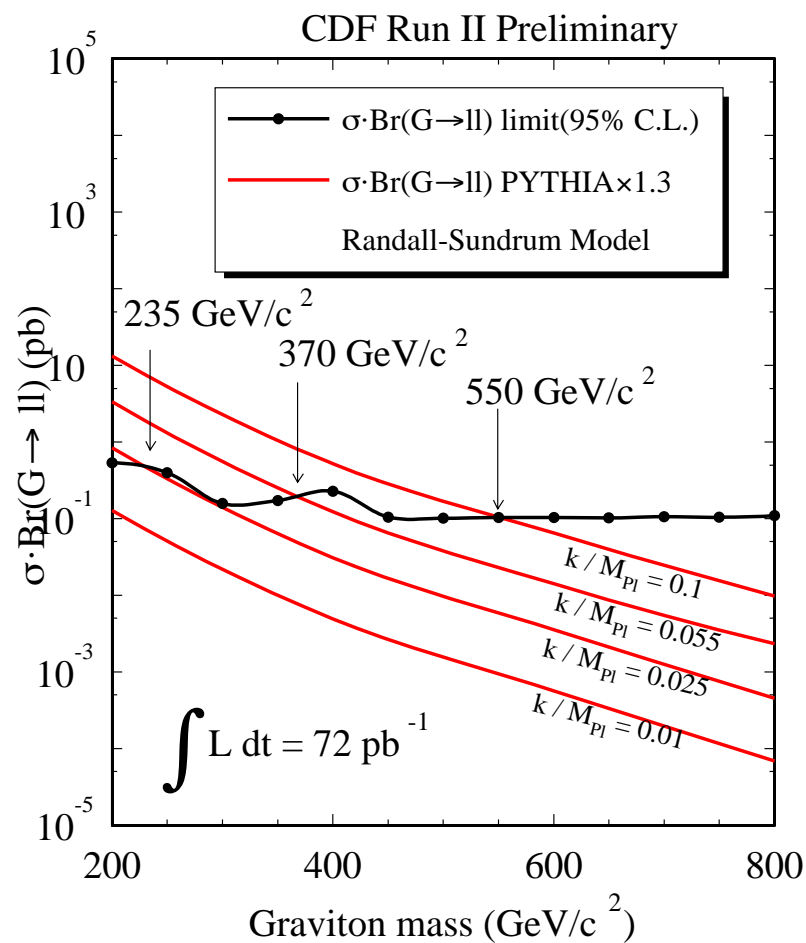

LEADING ORDER MC (CTEQ5L) + K-FACTOR

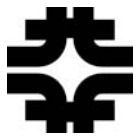

✓ CONCLUSIONS

□ SEARCHES IN THE DIJET CHANNEL

- ⊛ PROVIDED THE FIRST EXCLUSION BEYOND THE TeV LIMIT
- ⊛ ALL LIMITS HAVE IMPROVED WRT RUN I SEARCHES...
- ⊛ ...ALREADY WITH 75 pb^{-1}

□ SEARCHES IN THE DILEPTON CHANNEL

- ⊛ DIELECTRON CHANNEL AS SENSITIVE AS RUN I
 - ↪ INCREASED CROSS-SECTION COMPENSATES FOR LOWER LUMINOSITY
- ⊛ DIMUON CHANNEL PENALIZED BY TEMPORARY LOWER ACCEPTANCE
 - ↪ EXTENDED μ -CHAMBERS ACTIVATED ALMOST ONE YEAR AGO

□ CDF & DO ACTIVELY PROBING BEYOND THE SM HORIZONS

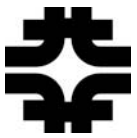

SEARCHES FOR NEW PARTICLES – SYSTEMATICS

NEW PARTICLES → DIJETS

Systematic Uncertainty in Limit on Cross Section

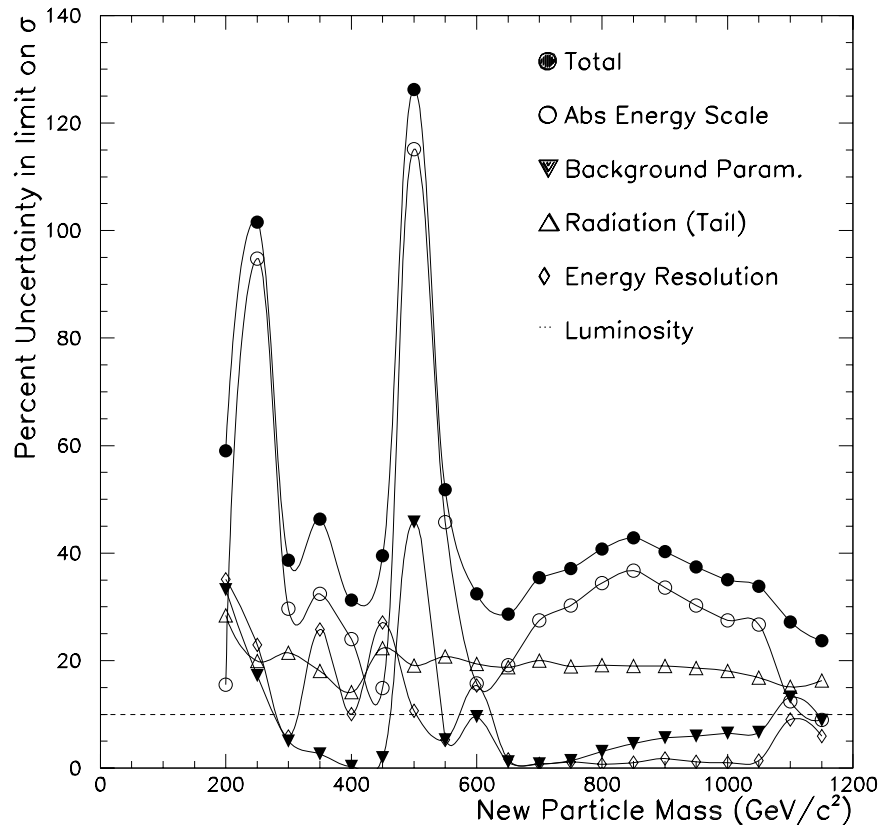

NEW PARTICLES → DIELECTRONS

LUMINOSITY	6%
ENERGY RESOLUTION	1.9% ÷ 3.5%
ENERGY SCALE	0.9% ÷ 1.7%
TOTAL CDF	~9%

K-FACTOR	5%
A_Z'/A_Z & PDF	2% ÷ 3%
TOTAL DO	~6%

NEW PARTICLES → DIMUONS

LUMINOSITY	6%
EFFICIENCY	6%
TOTAL	~9%

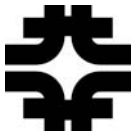

✓ SEARCHES FOR NEW PARTICLES – RUN I vs RUN II

NEW PARTICLE	DECAY	CDF EXCLUDED MASS [GeV/c ²]	
		RUN I	RUN II
AXIGLUON		$120 < M_A < 870$	$200 < M_A < 1130$
COLORON		–	$200 < M_C < 1130$
EXCITED QUARK	$X \rightarrow jj$	$200 < M_{q^*} < 560$	$200 < M_{q^*} < 760$
TECHNI- ρ		$320 < M_{\rho_T} < 480$	$260 < M_{\rho_T} < 640$
E ₆ DIQUARK		–	$280 < M_D < 420$
GAUGE BOSONS			
$W'_{SM-like}$	$W' \rightarrow jj$	–	$300 < M_{W'} < 410$
$Z'_{SM-like}$		$M_{Z'} < 690 \begin{smallmatrix} 655 \\ 590 \end{smallmatrix}$	$M_{Z'} < 665 \begin{smallmatrix} 650 \\ 455 \end{smallmatrix}$
Z'_χ		$M_{Z'} < 595 \begin{smallmatrix} 530 \\ 500 \end{smallmatrix}$	$M_{Z'} < 530 \begin{smallmatrix} 525 \\ 330 \end{smallmatrix}$
Z'_ψ		$M_{Z'} < 590 \begin{smallmatrix} 520 \\ 495 \end{smallmatrix}$	$M_{Z'} < 545 \begin{smallmatrix} 540 \\ 340 \end{smallmatrix}$
Z'_η	$Z' \rightarrow \ell\ell \begin{smallmatrix} ee \\ \mu\mu \end{smallmatrix}$	$M_{Z'} < 620 \begin{smallmatrix} 550 \\ 520 \end{smallmatrix}$	$M_{Z'} < 575 \begin{smallmatrix} 565 \\ 340 \end{smallmatrix}$
Z'_I		$M_{Z'} < 565 \begin{smallmatrix} 505 \\ 480 \end{smallmatrix}$	$M_{Z'} < 495 \begin{smallmatrix} 565 \\ 365 \end{smallmatrix}$
Z'_{LR}		$M_{Z'} < 630 \begin{smallmatrix} 565 \\ 530 \end{smallmatrix}$	–
Z'_{ALRM}		$M_{Z'} < 600 \begin{smallmatrix} 525 \\ 500 \end{smallmatrix}$	–

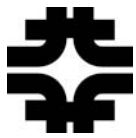

✓ SEARCHES FOR NEW PARTICLES – PROSPECTS

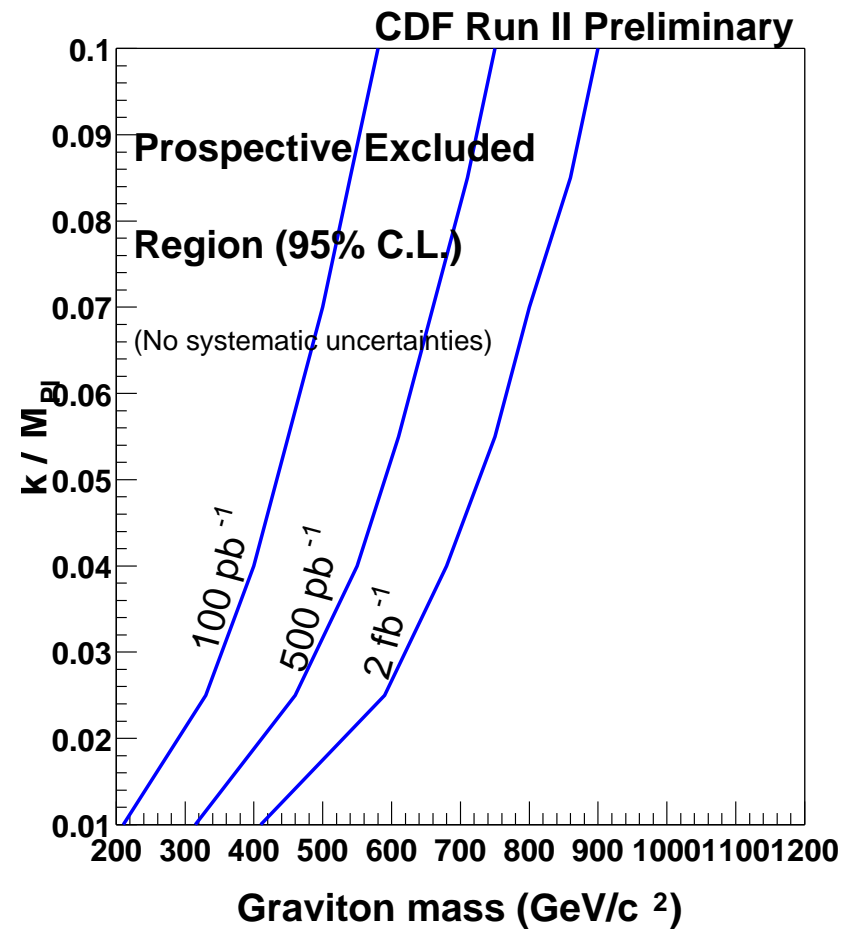
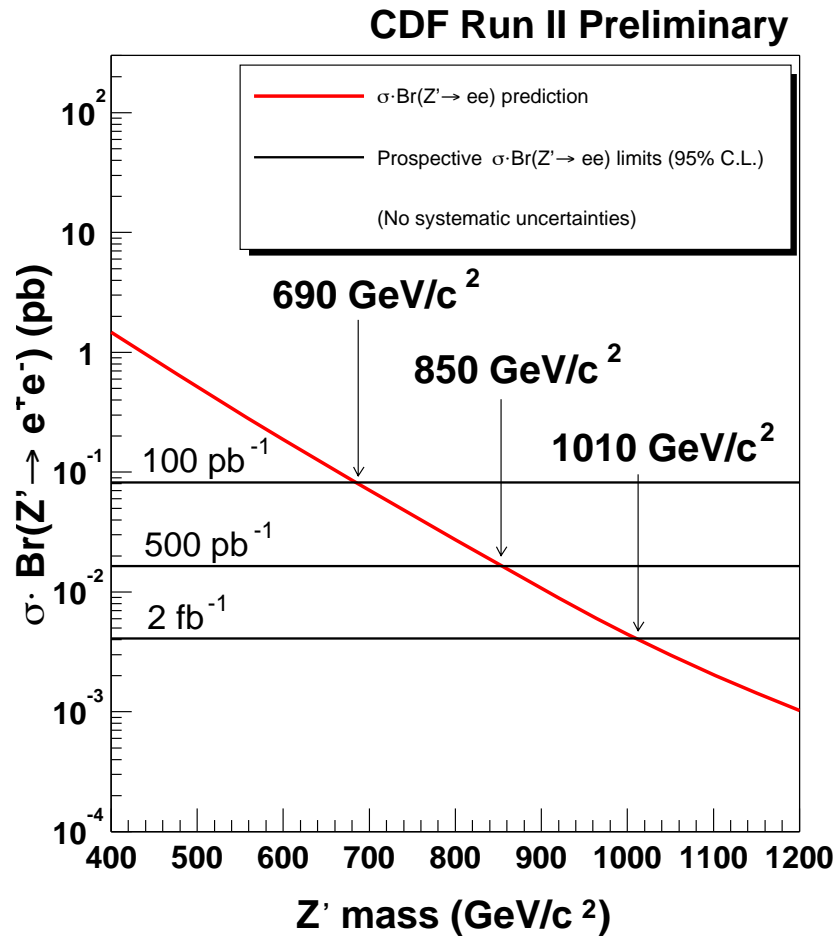

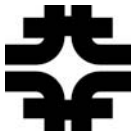

✓ SEARCHES FOR NEW PARTICLES – E_6 MODEL Z'

$$E_6 \rightarrow SO(10) \times U(1) \rightarrow SU(5) \times U(1)_\chi \times U(1)_\psi \rightarrow \underbrace{SU(3)_C \times SU(2)_L \times U(1)_Y}_{\text{SM}} \times U(1)_\chi \times U(1)_\psi$$

$U(1)_\chi, U(1)_\psi \longleftrightarrow$ TWO ADDITIONAL NEUTRAL VECTOR BOSONS (Z_χ, Z_ψ)

MASS EIGENSTATES: $Z'(\theta) = Z_\psi \cos \theta + Z_\chi \sin \theta$

$Z'(\theta)$	θ
Z'_χ	0
Z'_ψ	$-\pi/2$
Z'_η	$\sin^{-1} \sqrt{3/8}$
Z'_I	$\sin^{-1} \sqrt{5/8}$